

Port service quality (PSQ) and customer satisfaction: an exploratory study of container ports in Vietnam

Tien Minh Phan

Department of Business, Vietnam Maritime University, Haiphong, Vietnam

Vinh V. Thai

School of Accounting, Information Systems and Supply Chain, RMIT University, Melbourne, Australia, and

Thao Phuong Vu

Division of Business Logistics, Faculty of Marketing, Thuongmai University, Hai Phong, Vietnam

Abstract

Purpose – This study aims to investigate the concept of port service quality (PSQ) and examine its influence on customer satisfaction in the container port sector in Vietnam. Despite the importance of the maritime industry in which port is a critical sector in the national economy, there has been no research so far which examines what PSQ entails and how it affects customer satisfaction in the context of Vietnam.

Design/methodology/approach – Following a literature review, a conceptual model of PSQ and its influence on customer satisfaction was proposed. A survey questionnaire was then developed and piloted with senior executives who are working in various container shipping lines and logistics companies in Vietnam. The questionnaire was first designed in English and then refined through the process of translation and back-translation to ensure language non-discrepancies. The survey was administered to 200 members of Vietnam Shipowners' Association, Vietnam Logistics Associations and Vietnam Shippers' Council. By the cut-off date, 108 questionnaires were received, in which 99 valid replies were used for further analysis.

Findings – Results from this study reveal that PSQ is a construct of 4 factors and 16 items, and that enhanced PSQ will positively influence customer satisfaction, in which the outcomes of port service performance and its image would have the greatest impact. Interestingly, most items relating to social and environmental responsibility were dropped, and this result is expected in the context of a developing country like Vietnam.

Originality/value – Findings from this research may enhance port managers' understanding on areas of PSQ to improve so as to meet and exceed their customers' satisfaction.

Keywords Vietnam, Customer satisfaction, Container port, Port service quality

Paper type Research paper



1. Introduction

In the era of globalization, international trade transactions have been supported by global supply chains. In this respect, seaports play an important role as nodes for inbound and outbound flow of products. Initially, seaports were basically considered as a platform where cargoes are loaded/unloaded onto or from ship, having connectivity with other transport modes (Branch, 1986). As globalization progresses, the concept of seaport has been expanded and being integrated with a function of providing value-added services (e.g. packaging and consolidating cross-docking) (World Bank, 2007), thus contributing significantly to the global supply chains. Seaports are now increasingly involved in the effective management of product movements and information transfer. Therefore, any unexpected incidents, such as accidents or delays in cargoes loading and unloading, may cause interruption in those movements, resulting in failure of performance in other stages of the global supply chains. An inefficient outcome of seaport management certainly leads to the unhappiness of other stakeholders (e.g. shipping lines, shippers and logistics service providers) because of consequences they may have to bear as a result.

In Vietnam, the role of seaports in recent years has become increasingly important because of the surge in international trade volume particularly after Vietnam became a member of World Trade Organization in 2007. In recent years, Vietnam's seaports have showed an impressive and consistent growth in terms of throughput and were also highlighted as top logistics service expansion sector compared to others in the region. Vietnam's seaports system is developing fast with the throughput growth in the period 2010–2015 reaching 11.8%, doubling the average level of the world. In 2018, it was recorded that seaports in Vietnam handled 12,930,071 TEU (Vietnam Seaports Association, 2018), which reflected a sizable trade of containerized cargo in this country. However, Vietnam is still considered a developing country because of low average GDP per capital and thus more attention is often paid to economic rather than sustainable development in general and that in the maritime industry in particular.

Vietnam seaports system includes ports in three regions, namely, north, central and south, with three main ports being Hai Phong, Da Nang and Saigon, respectively. Among those, the ports of Hai Phong, Saigon and their respective satellite ports of Quang Ninh (e.g. Cai Lan International Container Terminal) and Vung Tau (e.g. Tan Cang – Cai Mep Thi Vai Terminal) account for 97% of the country's total container-handling volumes (Agency of Foreign Trade, 2018). Hai Phong Port is the national gateway to the northern part of Vietnam as well as southern China and currently consists of 14 terminals. Some of these terminals, which are operated by corporations such as Germadept, Vinconship and VIMC, annually handle about 500,000 TEUs according to the annual reports of these corporations. In addition, the new 14-meter-deep sea port of Lach Huyen has been recently constructed in Hai Phong, which started its operations since May 2018 and is capable of accommodating larger container vessels (i.e. 4,000–6,000 TEU), potentially accommodating up to 8,000 TEU vessels (Ship-Technology, 2019).

Meanwhile, the southern port market is currently dominated by Saigon New Port Corporation (SNP). Cat Lai Port, located in Hochiminh city and operated by SNP, accounted for 92% of container throughput in the south in 2018. Growing at a slightly slower speed than the other two strategic ports is the port system in Da Nang, which handles about 63% of container and 22% of bulk cargo volumes in this region (Nguyen and Ngo, 2017). In addition, this region is being invested with projects to develop Tien Sa terminal of Da Nang

Port as the regional node for trans-border transportation among Cambodia, Laos, Myanmar and Vietnam.

Generally, the port system in Vietnam includes three key seaport regions, which are fragmented into a number of ports and terminals managed by different port operators. This significantly stimulates competition among them. Furthermore, it is projected that some key Vietnamese seaports will compete with hubs in Singapore or China in the long run (Nguyen and Ngo, 2017). In a competitive environment, service quality is recognized as a determinant of market share, return on investment and cost (Burch *et al.*, 1995), thus playing an important role in port success. For that reason, researching about service quality dimensions of Vietnamese seaports and their impact on customer satisfaction is essential for their growth and competitive advantage. This is especially valid given the context of a developing country like Vietnam with unique political and socio-economical features which are also reflected in the distinctive features in terms of port governance, administration and management (Thai, 2017). A research on port service quality (PSQ) and customer satisfaction will therefore contribute to enrich the literature of PSQ management especially in the context of developing countries.

Obviously, apart from considerable investment in upgrading infrastructure and facilities, academic research on how to improve seaports' service quality is relatively scant, especially in the context of Vietnam. Furthermore, available studies on seaports worldwide as well as in Vietnam heavily concentrate on their impacts on national and regional economies, efficient operations and competitiveness. In the meantime, the number of studies on PSQ is relatively limited, especially in a developing country like Vietnam. Hence, this research aims to investigate PSQ constructs and their influence on customer satisfaction in Vietnam seaports system. In this paper, we propose a model of evaluating PSQ and its hypothesized relationships with customer satisfaction, and then validating this model based on data collected from a survey of seaports' customers in Vietnam.

The remaining sections of this paper are structured as follows. Section 2 focuses on reviewing literature of service quality, PSQ and customer satisfaction, upon which the conceptual model of PSQ is based. Section 3 provides details of research methodology, including the research framework, hypothesis development, methods of data collection and sampling. The analysis and findings are presented in Section 4, while research implications are discussed in Section 5. The paper concludes with the summary of findings and a brief elaboration on limitations and future research in Section 6.

2. Literature review

2.1 Review on port service quality measurement

Some scholars argued that quality of a service can be assessed by a set of specifications developed by the organization. In this connection, Cronin and Taylor (1992) introduced SERVPERF, arguing that customer preferences are more relevant to the long-term service quality than impending differences in expectations and performance. Hopkins *et al.* (1993) evaluated cognitive service quality in the logistics sector using the SERVQUAL model, and identified the meeting of customer expectations as the fundamental requirement for customer satisfaction. Another approach which is much more popularly applied is to compare the extent of customer experience with the level of his or her expectation of service quality as defined by Rushton *et al.* (2014). This idea is similar to the research of Parasuraman *et al.* (1985), who proposed the SERVQUAL model – one of the most commonly applied service quality measurement tools. SERVQUAL model covers five dimensions of quality, namely, tangibles, reliability, responsiveness, assurance and

empathy. These five dimensions can be differently interpreted when SERVQUAL is applied in different industries. However, those dimensions concentrate on assessing the process of delivering service. There are some other models of service quality measurement, such as those developed by Gronroos (1984) and Lehtinen and Lehtinen (1991). These two models have compensated SERVQUAL's shortage by adding outcomes-related components, for instance, technical and functional quality in the former, and process and output quality in the latter. Albeit these models have been applied in quality assessment in various fields, even in the port sector (Ugboma *et al.*, 2004; Hu and Lee, 2017), and there is still the need for construct and variable customization for each industry (Babakus and Boller, 1992; Caro and Garcia, 2007; Ladhari, 2008; Van Dyke *et al.*, 1997). Some scholars have proved that SERVQUAL is not suitable to some businesses, for example, corporate banks (Guo *et al.*, 2008) or supply chains (Seth *et al.*, 2006). This view was also echoed by Chowdhary and Prakash (2007) that general dimensions cannot reflect precisely the level of service quality, and thus industry-specific factors are needed. Also, another shortcoming of the SERVQUAL framework is that it was used to measure PSQ without taking into account the specifications of port operation and management (Lee *et al.*, 2013). Additionally, port service attributes could not be found or the necessity of reflecting the viewpoint of container carriers was not clearly illustrated in several papers using SERVQUAL model (Lee *et al.*, 2013). Meanwhile, Brady and Cronin (2001) defined the aspects of service quality as "relational quality," "result quality" and "physical environmental quality." Leveraging on this, Cho *et al.* (2010) defined sub-factors being introduced by Brady and Cronin as the internal capacity of a port or an "endogenous quality." Furthermore, the study is also supplemented by exploring the influence of cognitive service quality on customer satisfaction, loyalty and referral intentions. In terms of conducting research studies on PSQ, understanding port users' expectations and perceptions of service quality becomes crucial in light of the importance of ports (Ugoma *et al.*, 2004). This emphasis is highlighted in PSQ studies in both developing and developed countries.

Studies of service quality in the maritime sector in general, and in the port industry in particular, have not been widely conducted in the literature. Most of these studies focus much on port efficiency, selection of port or carrier and so on. The first studies on assessing port services could be dated back to the late 20th century, conducted by Foster (1979), Slack (1985) and Murphy *et al.* (1987). These researchers merged the two concepts of PSQ and port selection by asking surveyed participants to identify key factors for choosing a port. This approach does not match with the idea of customers' expectation and perception comparison mentioned above. Table 1 provides a summary of existing studies on PSQ dimensions.

According to Table 1, the criteria of PSQ measurement vary significantly from study to study. While some of these dimensions only suit specific sectors such as passenger port (e.g. parking facilities), others can hardly reflect service quality, focusing much on infrastructure and facilities of the port (e.g. available facilities) and pricing (e.g. ports costs). Another point which should be highlighted is that "social responsibility" has not yet been added in the above research, given that green advocacy and sustainable development have been increasingly prevalent in the port literature. Ports' customers (shippers, carrier, logistics providers, etc.) are increasingly concerned about green initiatives from ports, especially in the context of International Maritime Organization (IMO) 2020 regulations.

A model which was designed specifically for measuring service quality in maritime transport, ROPMIS, was introduced by Thai (2008) taking into account the aforesaid gaps in

Table 1.
Summary of studies
on PSQ dimensions

Studies	Dimensions of PSQ
Ha (2003)	Availability of port service information Geographical position Turn-around time of handling cargo at port Availability of facilities Management Service fees Convenience for customer
Pantouvakis (2010)	Services Security and safety Cleanliness Guidance-communication Parking facilities Information
Kolanovic <i>et al.</i> (2008)	Reliability Competence
Lee <i>et al.</i> (2013)	Timeliness Responsiveness Cooperation Infrastructure
Cho <i>et al.</i> (2010)	Price acceptability Endogenous quality Exogenous quality Relational quality

the literature. This model contains resources-, outcomes-, processes-, management-, image- and social responsibility-related service quality factors. Compared to earlier studies, this model adds new dimensions of management, image and social responsibility to comprehensively cover aspects of service quality in maritime transport. ROPMIS has been adapted in various studies on service quality in container shipping (Tepe, 2015; Le, Ho and Nguyen, 2018), tramp shipping (Thai *et al.*, 2014), passenger shipping (Thamrin, 2012), freight forwarding (Gil-Saura *et al.*, 2018) as well as container terminals and ports (Thai, 2015; Yeo *et al.*, 2016; Chang and Thai, 2016; Pham and Yeo, 2019) with high validity and reliability.

In these studies, in-depth interviews with senior executives and experts were often conducted to check the relevance of the variables in the specific maritime context, followed by quantitative results which confirmed the validity and reliability of variables and constructs. The model was also applied in a recent study by Nguyen (2015) to measure service quality and examine its effect on customer satisfaction of ports in the same system of Saigon Newport Corporation. For this reason, we also adopt this model in the current study, and revisions were made to suit the context of seaports in Vietnam. Compared to the earlier study on PSQ conducted in Vietnam, the current study shall encompass a wider population in which ports of all groups in Vietnam will be included in the research and not limited to those which belong to any specific port operator.

2.2 Customer satisfaction measurement

Customer satisfaction is initially considered as customers' assessment on a purchasing transaction (Anderson *et al.*, 1994), highlighted as the state of positive fulfillment when judging product, service or working relationship (Gaski and Nevin, 1985; Oliver, 1997;

Farrelly and Quester, 2005). Customer satisfaction concept generally includes two components, namely, pre-event expectations and post-event evaluation (Hill *et al.*, 2003). The result from a difference between these two items reflects whether customers are happy with the service or products they purchase.

There have been numerous papers and research works on the links between customer satisfaction and service quality. For example, Parasuraman *et al.* (1994), Brady and Robertson (2001), Santouridis and Trivellas (2010) and Liao (2012) proved that this was a positive relationship. This means that the better the quality of products or services, the more satisfied the customers. In the context of the transportation sector, the positive link between service quality and customer satisfaction was also elaborated in the work of Anderson *et al.* (2009) and Cao and Chen (2011) in their examination of transport by aircraft and train, respectively. There have also been several studies which examined this link in the port sector, most recently by Cho *et al.* (2010), Miremadi *et al.* (2011), Thai (2015), Yeo *et al.* (2016) and Chang and Thai (2016).

Although there are several studies on service quality and how it influences customer satisfaction, research focusing on service quality in the port sector, particularly its impacts on customer satisfaction is still limited. This also applies in the case of Vietnam as a developing country and thus this current study is a timely contribution to the relevant body of knowledge.

3. Methodology

3.1 Research context

The aim of this research is to assess the prospective causal relationship between service quality of seaports in Vietnam and the satisfaction of their customers encompassing shipping lines, shippers and who being on behalf of them to handle logistics activities (forwarder agents and logistics service providers). Vietnam's seaport system includes six seaport groups. The first group contains northern seaports (locating between Quang Ninh and Ninh Binh provinces); the second group consists of northern central seaports (situating between Thanh Hoa and Ha Tinh provinces); the third includes mid-central seaports (locating between Quang Binh and Quang Ngai provinces); the fourth group consists of southern central seaports (situating between Binh Dinh and Binh Thuan provinces); the fifth group includes southern seaports (Ho Chi Minh City and provinces of Dong Nai, Binh Duong and Ba Ria - Vung Tau); and the sixth group contains seaports in the Mekong Delta. The northern seaports of Vietnam play the crucial role as gateway connecting the country with Northeast Asian countries and territories such as China, Japan, South Korea and Hong Kong (FPT Research, 2017). Meanwhile, the southern seaports are strategically located linking Vietnam with other Association of Southeast Asian Nations countries and those in other continents. Currently, Vietnam has 45 seaports, 265 terminals and 402 berths for accommodating vessels with a total length of nearly 87,550 km. At present, there are 2 seaports of category IA (international gateway ports), 12 seaports of type I (general ports at regional focal economic regions), 18 seaports of type II (local general ports) and 13 seaports of type III (offshore oil and gas terminals) (Agency of Foreign Trade, 2018).

3.2 Background theory, conceptual framework and measures

This study is grounded in the well-known resource-based view theory, which postulated that the firm performs better than its competitors through unique and firm-specific resources that are costly for others to imitate and substitute (Barney, 1991; Madhani, 2010). The firm's resources include both tangible and intangible resources. In the context of

seaports, tangible resources refer to physical resources which consist of channel, berth, gates, container yard, forklifts, etc. (Wanke and Barros, 2015; Bichou, 2013), while intangible resources may exist in the form of knowledge, information and capabilities, to name just a few (Pak *et al.*, 2015). In this connection, the quality of port service can be considered a form of intangible resources, and it is essential to examine whether such a resource would contribute to enhance one of the most important aspects of port performance – customer satisfaction in this study.

Based on previous analyses, the ROPMIS model (Thai, 2008) is consistently used in terms of measuring PSQ accompanied by six PSQ dimensions below:

- (1) *Resources-related*: Readiness and availability of cargo handling facility, convenience of cargo track and trace, condition of infrastructure, etc.
- (2) *Outcome-related*: Just-in-time provision of service, consistency of service performance (time of delivery and acceptance), homogenous service supplied, safety assurance for cargoes, correctness of documents and diversification of service.
- (3) *Process-related*: Employees' attitude in serving customers, employees' interaction with customer needs, employees' profession and awareness about customer enquiries and needs and technological application in providing service to customers.
- (4) *Management-related*: Technological application in operations and management, performance in operations and management, understanding of customer needs and customer needs-oriented continuous improvement.
- (5) *Image/reputation-related*: Reputation for good relationship with other supply chain partners and reputation for service reliability.
- (6) *Social responsibility-related*: Safe and environmentally responsible operations and social responsibility fulfillment.

In a recent study (Thai, 2015), the resources-related quality dimension was removed because it influences others in the large extent. The new dimension, namely, “image and social responsibility” was introduced as the consequence of combining two separate dimensions of “image” and “social responsibility” when revising the model of PSQ. This combination was validated in the research of Thai (2015) and Yeo *et al.* (2015). In these studies, several variables which are used to analyze each PSQ dimension have been revised to reflect the distinctive context of the port sector. For instance, the initial “physical infrastructure” under the resources-related dimension of ROPMIS model was revised to include “physical infrastructures such as berths, yards, warehouses, distribution center and hinterland connection networks.”

It can be observed in the existing literature that the customer satisfaction construct is well developed. Besides, this also encompasses measurements of satisfaction being reflected by equipment and facilities, services, as well as overall satisfaction (Anderson *et al.*, 2009; Pantouvakis, 2010). Additionally, a primary logical inference is that customers just only maintain continuously their selection of the given service and propagandize positively about it to others only when they have the satisfaction with the service provided (Cao and Chen, 2011). For this reason, the current study also included these two measurement items in the customer satisfaction construct. Table 2 presents the conceptual framework for this research and summary of measures. The ROPMIS model of Thai (2008) and PSQ models of Thai (2015) and Yeo *et al.* (2016) are the fundamental models of service quality to be applied and

Research variables and measurement items	Abbreviation	References
<i>Outcomes-related PSQ factors (OC)</i>		
The port that we are using always provide fast service	OC1	Adopted from Thai (2008), Thai (2016) and Yeo <i>et al.</i> (2016)
The port that we are using always provide service in a reliable manner	OC2	
The port that we are using always ensure safety and security to our ships/shipments	OC3	
The port that we are using always produce error-free invoice and related documents	OC4	
The port that we are using always offers competitive price of service	OC5	
The port that we are using can always meet our service requirements anytime and anywhere we want	OC6	
<i>Process-related PSQ factors (PR)</i>		
The staff in the port that we are using always demonstrate professional attitude and behavior in meeting our requirements	PR1	
The staff in the port that we are using always respond quickly to our enquiries and requests	PR2	
The staff in the port that we are using always demonstrate good knowledge of our needs and requirements	PR3	
The level of information and communications technology (ICT) applications in customer service at the port that we are using is comprehensive	PR4	
<i>Management-related PSQ factors</i>		
The level of ICT applications in port operations and management at the port that we are using is comprehensive	MA1	
The port that we are using demonstrates high level of efficiency in operations and management	MA2	
The management in the port that we are using always demonstrate good knowledge and competence, including incident-handling capability	MA3	
The management in the port that we are using always demonstrate good understanding of our needs and requirements	MA4	
The port that we are using always collect our feedback about their services and reflect on their improvement	MA5	
The port that we are using continuously improve their customer-oriented operation and management processes	MA6	
<i>Image and social responsibility-related PSQ factors</i>		
The port that we are using demonstrates good relationship with other ports and land transport service providers	CSR1	
The port that we are using possesses positive reputation for reliability in the market	CSR2	

(continued)

Table 2.
Constructs and
measurement items

Research variables and measurement items	Abbreviation	References
The port that we are using always emphasizes on operations and work safety	CSR3	
The port that we are using demonstrates good record of operations and work safety	CSR4	
The port that we are using fulfill good social responsibility to their employees and other stakeholders	CSR5	
The port that we are using always emphasizes on environmentally responsible operations	CSR6	
The port that we are using has in place the environmental management system	CSR7	
<i>Satisfaction with PSQ</i>		
Overall, we are satisfied with the facilities, equipment and other infrastructures of the port that we are using	CS1	Anderson <i>et al.</i> (2009), Pantouvakis (2010) and Cao and Chen (2011)
Overall, we are satisfied with the management and employees of the port that we are using	CS2	
Overall, we are satisfied with the service quality of the port that we are using	CS3	
We will refer services of the port that we are using to our business partners	CS4	
We will continue using services of the port that we are using	CS5	
Notes: MA = management; PR = process; OC = outcome; CSR = corporate social responsibility; CS = customer satisfaction		

Table 2.

adopted in this study, in which the measurement items of quality dimensions in these models are also used but amended to be in relevant to the Vietnamese port context in our model of PSQ.

3.3 Research hypotheses

The purpose of this research focuses on examining how the satisfaction of port customers is influenced by PSQ with a four-dimensional construct. As a result, four hypotheses were developed as follows:

- H1. Outcomes-related PSQ positively influences customer satisfaction in Vietnamese seaports.
- H2. Process-related PSQ positively influences customer satisfaction in Vietnamese seaports.
- H3. Management-related PSQ positively influences customer satisfaction in Vietnamese seaports.
- H4. Image and social responsibility-related PSQ positively influences customer satisfaction in Vietnamese seaports.

3.4 Sampling and data collection

The data that were used to examine how PSQ affects port customers' satisfaction were obtained from a national survey with port customers including shipping lines and shippers and/or their representatives such as freight forwarders and logistics service providers. The population that was selected to conduct the survey includes three customer groups in three regions of north, central and south of Vietnam. The first group is of domestic shipping lines which are members of Vietnam Shipowners' Association (VSA). In total, 30 questionnaires were delivered in person to representatives of VSA's members who are holding senior positions in business department, operations and customer service in their respective organizations. Meanwhile, the second group of prospective respondents includes 120 members of Vietnam Logistics Association to which the questionnaires were distributed via email. The same method of survey administration (email delivery) was also applied to distribute the questionnaire to 50 members of the third group, Vietnam Shippers' Council.

The non-probability random sampling is the method selected for the national survey. The questionnaires were delivered to prospective organizations from October 2018 to February 2019. Prior to this, the questionnaire, which was initially designed in English, was translated into Vietnamese, then back-translated into English. The back-translated English version was compared with the original one to ensure thematic consistency. Next, the Vietnamese version of the questionnaire was piloted with several senior executives that are holding senior managerial positions in various container shipping lines and logistics firms in Vietnam. Only when this was done, the Vietnamese version of the questionnaire was administered for the survey. The main contents of the questionnaire consist of two main parts. The first part comprises 28 statements corresponding to 4 variables of PSQ and customer satisfaction. The second part collects demographic information (type of business, name of port and region, experience and current designation of respondents) for classification purpose. Likert scale ranging from 1 to 5 is used, with "1" indicating "Strongly disagree" and "5" denoting "Strongly agree." By the cut-off date, the authors collected a total of 108 questionnaires from respondents, in which 99 valid replies were used for further analysis, yielding a response rate of 49.5%. About 30% of respondents are currently working in shipping companies, while 56% and 14% are freight forwarders/logistics service providers and shippers, respectively. Additionally, 47% of respondents have less than 5 years of working experience, 35% of respondents have 5 to 10 years of experience, while 18% of the remaining respondents have had more than 10 years of experience. It can be seen from these descriptive statistics that the respondents participating in this research are well eligible given their work experience in the maritime industry.

4. Analysis of results

4.1 Factor analysis of the port service quality model

Exploratory factor analysis (EFA) and Cronbach's alpha are the traditional tools being used to test how well the measured variables represent the number of constructs by measuring the validity and reliability. Several rounds of EFA were run using SPSS Version 20 software to derive the most accurate results and remove inconsistent variables with factor loading lower than 0.5. Table 3 reveals that the strength of inter-correlations, which is assessed by Bartlett's test of sphericity and the Kaiser-Meyer-Olkin (KMO) measure of sampling adequacy was good. The KMO

MABR
6,1

82

index is 0.882, greater than the normally suggested minimum value of 0.60 (Hair *et al.*, 1995), and Bartlett's test of sphericity is significant ($p = 0.000$), indicating the suitability of a factor analysis. The factor analysis adopts the principal component analysis (PCA) technique and applies the varimax with Kaiser normalization approach. In the EFA process, seven items were removed, including PR4, MA2, MA3, MA6, CSR5, CSR6 and CSR7 as the conceptual meaning of the factor representing them is not jeopardized because of their absence. The last round of factor analysis of 21 measurement items found 5 components with eigenvalues above 1, explaining 70.054% of the variance (Table 4). This analysis also produces a rotated component matrix which demonstrates how each measurement item is loaded on each of the factors (Table 5).

Table 3.
KMO and Bartlett's
test

KMO measure of sampling adequacy	0.882
<i>Bartlett's test of sphericity</i>	
Approx. chi-square	1320.660
df	210
Sig.	0.000

Table 4.
Total variance
explained

Component	Total	Initial eigenvalues			Total variance explained			Rotation sums of squared loadings		
		% of variance	Cumulative %	Total	Extraction sums of squared loadings		Total	Rotation sums of squared loadings		
					% of variance	Cumulative %		% of variance	Cumulative %	
1	9.721	46.289	46.289	9.721	46.289	46.289	3.696	17.598	17.598	
2	1.513	7.206	53.494	1.513	7.206	53.494	3.447	16.417	34.014	
3	1.380	6.569	60.063	1.380	6.569	60.063	2.870	13.669	47.683	
4	1.075	5.119	65.182	1.075	5.119	65.182	2.590	12.332	60.015	
5	1.023	4.872	70.054	1.023	4.872	70.054	2.108	10.039	70.054	
6	0.884	4.210	74.265							
7	0.743	3.539	77.803							
8	0.700	3.335	81.138							
9	0.590	2.808	83.946							
10	0.507	2.415	86.361							
11	0.456	2.170	88.531							
12	0.408	1.941	90.473							
13	0.355	1.692	92.164							
14	0.319	1.519	93.684							
15	0.273	1.299	94.983							
16	0.226	1.077	96.060							
17	0.212	1.010	97.070							
18	0.189	0.902	97.972							
19	0.173	0.822	98.794							
20	0.144	0.685	99.480							
21	0.109	0.520	100.000							

Note: Extraction method: PCA

	1	2	Component 3	4	5
CS3	0.730				
CS2	0.720				
CS5	0.714				
CS4	0.712				
CS1	0.690				
OC2		0.682			
OC6		0.671			
OC5		0.663			
OC4		0.659			
OC3		0.610			
OC1		0.602			
CSR2			0.789		
CSR3			0.777		
CSR1			0.659		
CSR4			0.615		
PR3				0.791	
PR1				0.782	
PR2				0.707	
MA5					0.757
MA4					0.724
MA1					0.671

Notes: Extraction method: PCA. Rotation Method: Varimax with Kaiser normalization. ^aRotation converged in seven iterations

Table 5.
Rotated component
matrix^a

Moreover, we can also evaluate the validity and reliability by confirmatory factor analysis (CFA). Based on the results of EFA, the validity and reliability of the extracted 4-factor PSQ model of 21 items and customer satisfaction of 5 items were conducted using CFA in the current study (Churchill, 1991). The results of this measurement model are presented in Figure 1 and Table 6. Looking at the results of CFA summarized in Table 6, it can be seen that the standardized loadings for all items are above 0.6, reflecting a good correlation between these observed items and the latent variables. These obtained results are suitable as these values are higher than recommended minimum value of 0.50 (Bagozzi *et al.*, 1991). Meanwhile, Litwin (1995) stated that the success of a social scientific research significantly depends on many factors besides accurate set of research tools and consistent sampling methods. For this reason, the comparative fit index (CFI), goodness-of-fit (GFI) index, composite reliability (CR), average variance extracted (AVE), maximum shared squared variance (MSV) and average shared squared variance (ASV) are examined to verify the convergent and discriminant validity, as well as CR of the measurement model (Hair *et al.*, 2010). According to Bollen (1989, p. 27), fit indices of CFI as low as 0.85 are “reasonable” for the model. Hair *et al.* (2010) also suggested the threshold for key fit indices e.g. GFI index should be more than 0.80 (good level), CR should be greater than 0.7, while there is no convergent validity issue when CR is bigger than AVE and AVE is greater than 0.5. Meanwhile, the discriminant validity is confirmed when both MSV and ASV are smaller than AVE. The results in Tables 6 and 7 show that no CR value is smaller than 0.7, all AVE values are bigger than 0.5 (convergent validity) and AVE

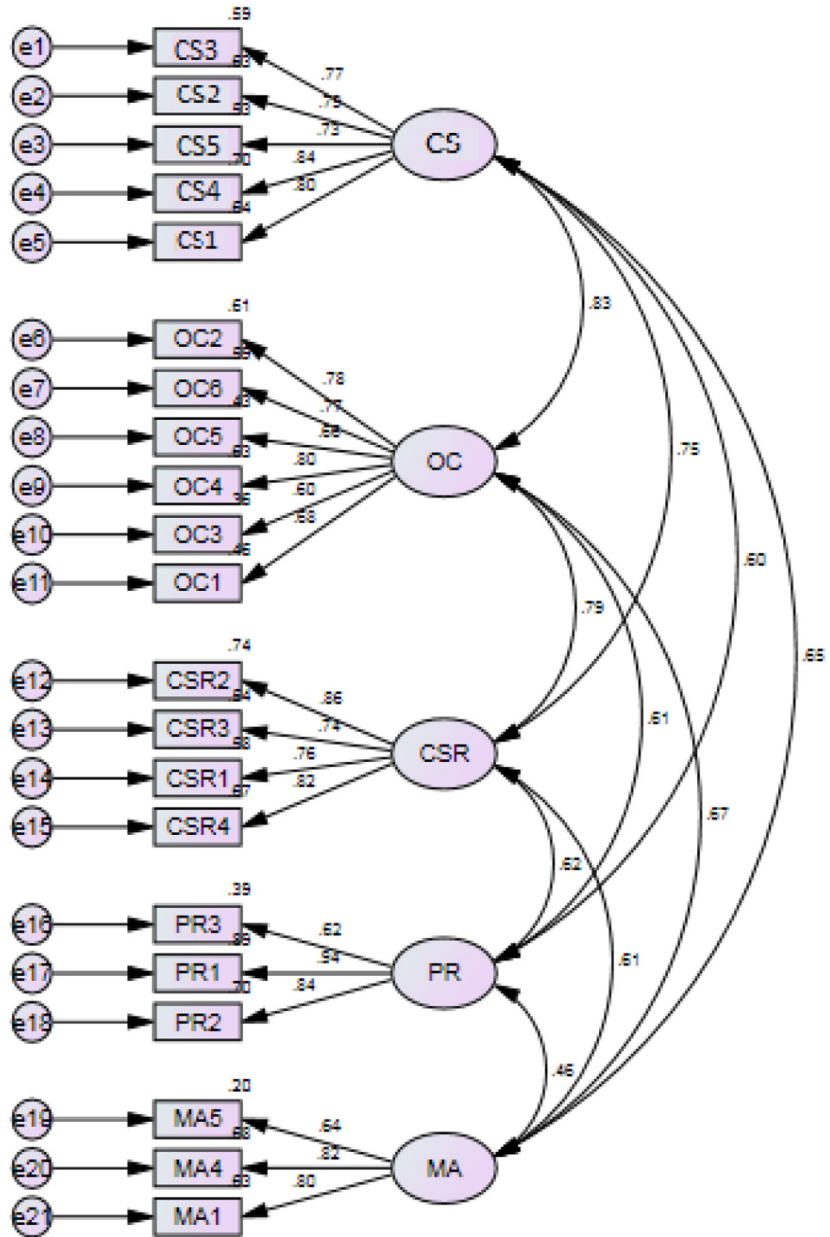

Figure 1.
PSQ and customer
satisfaction
measurement model
based on CFA

Table 6.

Results of CFA and scale reliability

Constructs	Variables	Standardized loadings	SMCs	AVE	Cronbach's α
Outcomes	OC1	0.68	0.46	0.513	0.858
	OC2	0.78	0.61		
	OC3	0.60	0.36		
	OC4	0.80	0.63		
	OC5	0.66	0.43		
	OC6	0.77	0.59		
Process	PR1	0.94	0.89	0.659	0.832
	PR2	0.84	0.70		
	PR3	0.62	0.39		
Management	MA1	0.80	0.63	0.503	0.722
	MA4	0.82	0.68		
	MA5	0.64	0.20		
Image and social responsibility	CSR1	0.76	0.58	0.637	0.872
	CSR2	0.86	0.74		
	CSR3	0.74	0.58		
	CSR4	0.82	0.67		
Customer satisfaction	CS1	0.80	0.64	0.619	0.889
	CS2	0.79	0.63		
	CS3	0.77	0.59		
	CS4	0.84	0.70		
	CS5	0.73	0.53		

Notes: $\chi^2/df = 1.646$, RMR = 0.051, GFI = 0.802, TLI = 0.889, CFI = 0.906 and RMSEA = 0.081; SMC = squared multiple correlation

Table 7.

Results of reliability and validity tests in CFA

	CR	AVE	MSV	ASV
Image and social responsibility	0.875	0.637	0.203	0.152
Outcomes	0.862	0.513	0.289	0.189
Process	0.850	0.659	0.062	0.052
Management	0.740	0.503	0.054	0.044
Customer satisfaction	0.890	0.619	0.289	0.262

values are bigger than all those of MSV and ASV (discriminant validity). These observed results prove that the required thresholds for reliability and validity in CFA are ensured for all factors extracted. Thus, the overall GFI of the model of 5 factors and 21 items is properly assured and the model is reliable and valid as an acceptable representation of the hypothesized model of PSQ and customer satisfaction in the context of Vietnam.

4.2 Impact of port service quality on customer satisfaction

To investigate the influence of service quality (independent variables) on customer satisfaction (dependent variable), the multiple regression was used with the confidence level of 95%. Given the sample size, it is deemed inappropriate to use structural equation modeling, and the deployment of multiple regression analysis in this study is also consistent to that in the previous research. [Tables 8](#) and [9](#) illustrate

the analysis results. All four factors of PSQ could be included in the regression equation as they match the entry requirements. Considering the result gained from multiple regression analysis, it can be seen that a suitable correlation between the dependent variable (customer satisfaction) and four predictors with the value of the multiple R ($R = 0.780$) is achieved, and this is statistically significant ($p = 0.000$). In addition, the adjusted R^2 value is 0.591, indicating that about 59.1% of variance of the dependent variable (customer satisfaction) in this regression analysis can be explained by those of the independent variables (four predictor variables). The Durbin–Watson index is 1.546 being in the range from 1.5 to 2.5, meaning no autocorrelation problem exists.

As the value of significance tests of the regression demonstrating the coefficients of independent variables are all less than 0.05, these independent variables have meaningful explanations for the dependent variable, and no variables are excluded from the model. Additionally, there is a positive influence on customer satisfaction observed from all four predictors. Specifically, the greatest positive influence on customer satisfaction ($\beta = 0.538$) belongs to the outcomes-related PSQ factor, while image and social responsibility-related PSQ ($\beta = 0.450$) and process-related factor ($\beta = 0.248$) stand at the second and third position, respectively. Standing in the last position is management-related ($\beta = 0.233$) factor. Given the beta values and significance (p -values) of the multiple regression test, it can be concluded that all four hypotheses in this research are supported, confirming that the PSQ of outcomes-based, image and social responsibility-based, process-based and management-based factors all have positive influence on customer satisfaction in Vietnamese seaports.

Generating the same result as the research of [Thai \(2015\)](#), outcomes-related PSQ factor has the most positive influence on customer satisfaction. However, it is interestingly found that the second most important factor affecting customer satisfaction is image and social responsibility. It is undeniable that ports play a crucial role as an integrated node in global supply chains, and thus they should concentrate on all factors of PSQ as an all-rounded approach to managing service quality. In accordance with the general theory of service quality, the experience of

Table 8.
Model summary –
coefficient of
determination

R	R^2	Adjusted R^2	Std. error of the estimate	Durbin–Watson
0.780 ^a	0.608	0.591	0.63921171	1.546

Notes: ^aPredictors: (Constant), MA, PR, CSR and OC. ^bDependent variable: CS

Table 9.
Model summary –
regression
coefficients

Model	Standardized coefficients beta			t	Sig.
(Constant)	1.935E-17	0.064		0.000	1.000
OC	0.538	0.065	0.538	8.334	0.000
CSR	0.450	0.065	0.450	6.969	0.000
PR	0.248	0.065	0.248	3.845	0.000
MA	0.233	0.065	0.233	3.611	0.000

Note: ^aDependent Variable: CS

user with the service is fundamentally shaped by encountering the outcome generated from the service. Thus, perceived service quality can be derived through comparing with the customer's service expectation. Besides, it is also worth noticing that the image and social responsibility-related factor of PSQ deserves its second important position, thanks to its huge contribution to port sustainability nowadays; although, in this research, only those items measuring the port's image were retained. It is evidenced that the reputation elements in the image and social responsibility-related factor of PSQ are the desirable elements of all business organizations in general and seaports in particular. Reputation is absolutely one of the most efficient tools for boosting ports' brand equity but owning a positive reputation is not easily attained without implying the emphasis on the port's corporate social performance as an important service quality enabler. This finding is crucial as it proves a pre-conception that, apart from reputation for reliability, safe and environmentally responsible operations are also essential to the quality service in the maritime industry, including that of ports. This industry frequently encounters a number of maritime accidents and incidents recorded daily which often cause the disasters affecting adversely the maritime ecosystem and surrounding areas. In terms of ports, customers' perception of quality can be easily affected by the performance being relevant to reliability and safe and environmentally responsible operations. Indeed, ports around the world have been also aware of this issue, for instance, the biggest seaports worldwide currently are racing for automated and smart port concepts, which encourage and incentivize ships to use alternative and green energy and unmanned vehicles and are in line with IMO 2020 requirements. For example, the "Ghost Port Concept" has been used to refer to Qingdao in China and Singapore, where there is almost no presence of human (Yun, 2017). For this reason, it is important to recognize that image and social responsibility-related factor positively influences customer satisfaction. Furthermore, this positive effect also contributes to justify port's investment in this aspect.

5. Discussion and implications

This paper validates the dimensions of PSQ model constructed from the generic models in the research of Thai (2008, 2015). Besides, in the context of a developing country like Vietnam, the investigation of how the dimensions of PSQ model influence customer satisfaction in the port sector is also carried out. Through the aforementioned analyses, it was unveiled that PSQ in Vietnam is a 4-dimensional construct consisting of 16 items relating to outcomes, process, management and image and social responsibility. It was also found that PSQ positively influences the satisfaction of ports' customers, in which outcomes-related factor plays the most influential role, followed by image and social responsibility factor. The next paragraphs discuss the implications and recommendations to improve the customer satisfaction of port services in Vietnam.

5.1 Improving port service outcomes

Regarding the outcome-related PSQ factor, it is suggested that the senior management of seaports in Vietnam should improve the promptness in carrying out their port services. It is widely agreed both in the literature and port management practice that ship owners and operators always want their vessels to be dispatched as soon as possible, as berthing at ports for a long time costs a huge amount of money and is not economically efficient for them. This is also one of the most important factors for these customers to decide whether or not to bring their vessels into a port.

Similarly, shippers and their representatives (i.e. freight forwarders and other logistics service providers) may not prefer a port whose cargo's dwell-time is lengthy. Therefore, to meet the demand of these port customers, the operations department of any seaport would need to significantly outline detailed berth, ship and yard planning well in advance of vessel berthing (depending on the quality of human resource and computer software available at the port). Currently, the terminal operations system has been installed at many seaports in Vietnam to facilitate the operational activities of these ports. For this reason, there is the need to educate and train more staff and stevedores working at ports on technicalities in using the software and other operations. However, it was mentioned earlier in the introduction section that seaports in the north of Vietnam possess distinctive features compared to those in the south. Specifically, the concentration of seaports in the south and fragmentation of those in the north leads to the discrepancy in applying technology. Such a fragmentation and non-unification also reflect a piecemeal mindset in policy and management planning in Vietnam in several economic sectors, including that in the national logistics (Banomyong *et al.*, 2015) and seaport (Thai, 2017) systems. Because of the fragmentation, the seaport system in the North of Vietnam faces difficulties in unifying interchange information systems between seaports, shipping lines and other dry ports and inland container terminals. In this context, it is strongly recommended that the northern seaports of Vietnam should, under the guidelines of relevant government agencies i.e. Ministry of Transport and Vietnam Maritime Administration as well as professional peak body i.e. Vietnam Seaports Association, discuss and implement various measures for smooth application of technology in ports. For example, uniform standards and operating regulations should be established in ports which will then facilitate the unobstructed flows of ship and cargo movements, thus reducing turnaround time for ships and dwell-time for cargoes, and improving service quality for port users. This is important given that the efficiency of seaports especially container terminals is associated with their technical and technological efficiencies (Yang and Yip, 2019). Meanwhile, with a higher proportion of electronic commerce port transactions in the south, seaports in this area should pay more attention on measures to enhance the security of all electronic transactions against cyber-security attacks.

Besides, for all seaports in Vietnam, the efficiency in shipment delivery and receipt and the price of these services also inevitably contribute to improve the outcomes of port services. Therefore, especially in this era of industrial revolution 4.0 (IR4), which includes Internet of Things, robotics and automation, the other recommendation to all ports and terminals in Vietnam is to effectively combine both human resource effectiveness and technology advancements to enhance port operational efficiency and service quality.

5.2 Improving port image, social responsibility and management

In terms of image and social responsibility, we offer recommendations relating to two elements being associated with this factor, namely, reputation and environment. Reputation reflects the image of the port, and significantly influences the subconscious feeling of customers when deciding to use the service at a certain port. Obviously, the reputation of a port could not be enhanced without customers' positive experience of its service quality, and in the era of IR4, just a negative customer experience can be easily propagandized to the community with incredibly fast speed through social media. Hence, the responsibility of senior managements in a port is

inevitably crucial, as they should set the role model of a leader to inspire employees to follow, especially when it comes to activities to enhance the port's service quality.

In terms of the environmental aspect, this has always been an issue of much public concern globally; however, it has not been paid much attention in the context of maritime activities in Vietnam compared to profit. This is evident from the findings of this research in which all items related to social and environmental responsibility were dropped. With the new IMO 2020 (low sulfur fuel regulation), the issue of lowering and limiting harmful effects of economic activities on the environment has increasingly become critical. In the seaport sector, many seaports worldwide, such as Rotterdam and Long Beach, have been supplying liquefied natural gas and electricity to all vehicles and equipment (Port of Long Beach, 2020). Moreover, Rotterdam and Gothenburg ports provide incentives in terms of discount of port dues and charges for vessels berthing at port that are operated by clean or low sulfur fuel (Port of Gothenburg Port Tariff for 2018 and Port of Rotterdam, General Terms and Conditions Including Port Tariffs). As such, environmental education and implementation of environmental friendly measures in ports should be the pivotal solution for improving port image and social responsibility in Vietnamese seaports. These will help contribute to Vietnam Green Growth Strategy (GGS), which includes the measures necessary to achieve sustainable development and reduce greenhouse gas emissions, and indicates the direction of measures that should be implemented in stages into the future (Climate and Development Knowledge Network, 2013). Implementing GGS and Green Growth Action Plan is critical for the Government of Vietnam, and seaports undoubtedly play an essential role in this respect.

Previous research highlighted that social and environmental responsibility PSQ elements seem to affect customer satisfaction in developed countries of Singapore and South Korea (Thai, 2015; Yeo *et al.*, 2016). In these port areas, environmental criteria in seaport activities have always been highly appreciated by port users. In contrast, some social responsibility-related indicators in port operations seem to be ignored by both port users and port service providers in Vietnam. Indeed, applying these in the context of Vietnamese seaports seems to be difficult given the implied cost constraints. Nevertheless, a suitable suggestion which can be applied now in seaports of Vietnam is the use of sewage disposal treatment (for ballast water) of vessels berthing at these seaports.

6. Conclusion, limitation and future research

The impact of service quality on customer satisfaction in the port sector is an under-researched area in the literature with only a few studies conducted quite recently, and scant research was found in the context of developing countries like Vietnam. Based on the results obtained from this research, it is evidenced that there are four factors contributing to PSQ, and customer satisfaction is significantly influenced by the enhancement of PSQ, in which the greatest impact is from the outcomes performance of port service. It can be seen from the findings of this research that there are academic and managerial implications, both in terms of contribution to knowledge and practical applications. First, this research contributes to enhance a comprehensive understanding of service quality as a key element of marketing strategy, especially in the context of the seaport sector in a developing country like Vietnam. The results affirm the significant and positive impacts of four PSQ factors, namely, outcomes, process, management, and image and social responsibility, which confirm the multi-dimensional nature of service quality on customer satisfaction. Second, some

managerial and policy recommendations can also be derived from findings of this research. On the one hand, port managers in Vietnamese seaports are provided with guidelines on which areas of PSQ to focus their attention on so as to enhance their customers' satisfaction. Specifically, improvements in various aspects of outcomes-related PSQ factors, i.e. timeliness, reliability, shipment safety and security, price and flexibility, should be made as these were perceived by port customers as critical contributors to their satisfaction with a port's service quality. Besides, as port customers in Vietnam also appreciate the relationship that a port builds and maintains with its maritime supply chain partners, its operations and work safety as well as reputation for reliability in the market, policies and strategies for a more comprehensive and meaningful collaboration with other port stakeholders will be critical to a port's performance in terms of service quality and customer satisfaction. This is especially important for seaports in the North of Vietnam to overcome the fragmentation and non-unification in port development which is partly because of the absence of the implementation of "port authority" similar to that elsewhere in the world (Thai, 2017). Relevant government agencies i.e. the Ministry of Transport and Vietnam Maritime Administration therefore should look into this issue seriously and provide prudent guidelines for various port operators. Meanwhile, for seaports in the south, more attention should be focused specifically on the next stage of development. Whereas seaports participate more intensively in e-commerce based business, and thus important issues such as cyber-security and diversification of port services would be needed to enhance more values for port customers.

Despite the significance of this study's findings, both in terms of theory building and managerial and policy implications, the generalization of this study should be done with caution. Being a developing country with unique political and socio-economic systems which are different from those of other emerging economies, the governance, administration and management of seaports in Vietnam possess some distinctive features (e.g. lack of "port authority" mentioned earlier) which may affect port customer satisfaction in some different ways. Therefore, it is recommended that the conceptual model developed in this research should be further tested in the context of other developing countries so as to improve the validity and reliability of the study instrument and enrich the theory of PSQ accordingly.

References

- Agency Of Foreign Trade. (2018), "Ministry of industry and trade of the socialist republic of Vietnam", Vietnam Logistics Report 2018, Ministry of Industry and Trade Press, Hanoi.
- Anderson, E.W., Fornell, C. and Lehmann, D.R. (1994), "Customer satisfaction, market share and profitability: findings from Sweden", *Journal of Marketing*, Vol. 58 No. 3, pp. 53-66.
- Anderson, S.W., Baggett, L.S. and Widener, S.K. (2009), "The impact of service operations failures on customer satisfaction: evidence on how failures and their source affect what matters to customers", *Manufacturing and Service Operations Management*, Vol. 11 No. 1, pp. 52-69.
- Babakus, E. and Boller, G.W. (1992), "An empirical assessment of the SERVQUAL scale", *Journal of Business Research*, Vol. 24 No. 3, pp. 253-268.
- Bagozzi, R.P., Yi, Y. and Phillips (1991), "Assessing construct validity in organizational research", *Administrative Science Quarterly*, Vol. 36 No. 3, pp. 421-458.
- Banomyong, R., Thai, V.V. and Yuen, K. (2015), "Assessing the national logistics system of Vietnam", *The Asian Journal of Shipping and Logistics*, Vol. 31 No. 1, pp. 21-58.

- Barney, J.B. (1991), "Firm resources and sustained competitive advantage", *Journal of Management*, Vol. 17 No. 1, pp. 99-120.
- Bichou, K. (2013), "An empirical study of the impacts of operating and market conditions on container-port efficiency and benchmarking", *Research in Transportation Economics*, Vol. 42 No. 1, pp. 28-37.
- Bollen, K.A. (1989), *Structural Equations with Latent Variables*, Wiley, New York, NY.
- Brady, M.K. and Cronin JR, J.J. (2001), "Some new thoughts on conceptualizing perceived service quality: a hierarchical approach", *Journal of Marketing*, Vol. 65, pp. 34-39.
- Brady, M.K. and Robertson, C.J. (2001), "Searching for a consensus on the antecedent role of service quality and satisfaction: an exploratory cross-national study", *Journal of Business Research*, Vol. 51 No. 1, pp. 53-60.
- Branch, A.E. (1986), *Elements of Port Operation and Management*, Chapman and Hall, London.
- Burch, E., Rogers, H.P. and Underwood, J. (1995), "Exploring SERVPERF: an empirical investigation of the importance-performance", *Service Quality Relationship in the Uniform Rental Industry*, available at: <http://saber.uca.edu/docs/proceedings11/>
- Cao, C. and Chen, J. (2011), "An empirical analysis of the relationship among service quality, customer satisfaction and loyalty of high speed railway based on structural equation model", *Canadian Social Science*, Vol. 7 No. 4, pp. 67-73.
- Caro, L.M. and Garcia, J.A.M. (2007), "Measuring perceived service quality in urgent transport service", *Journal of Retailing and Consumer Services*, Vol. 14 No. 1, pp. 60-72.
- Chang, C.-H. and Thai, V.V. (2016), "Do port security quality and service quality influence customer satisfaction and loyalty?", *Maritime Policy and Management*, Vol. 43 Nos No. 6, pp. 720-736.
- Churchill, G.A. (1991), *Marketing Research: Methodological Foundations*, The Dryden Press, London.
- Cho, C.H., Kim, B.I. and Hyun, J.H. (2010), "A comparative analysis of the ports of Incheon and Shanghai: the cognitive service quality of ports, customer satisfaction, and post-behaviour", *Total Quality Management and Business Excellence*, Vol. 21 No. 9, pp. 919-930.
- Chowdhary, N. and Prakash, M. (2007), "Prioritizing service quality dimensions", *Managing Service Quality: An International Journal*, Vol. 17 No. 5, pp. 493-509.
- Climate and Development Knowledge Network (2013), "FEATURE: Vietnam's national green growth strategy", available at: https://cdkn.org/2013/04/feature-vietnams-national-green-growth-strategy/?loclang=en_gb
- Cronin Jr, J.J. and Taylor, S.A. (1992), "Measuring service quality: a reexamination and extension", *Journal of Marketing*, Vol. 56 No. 3, pp. 55-69.
- Farrelly, F.J. and Quester, P.G. (2005), "Examining important relationship quality constructs of the focal sponsorship exchange", *Industrial Marketing Management*, Vol. 34 No. 3, pp. 211-219.
- Foster, T.A. (1979), "What's important in a port", *Distribution Worldwide*, Vol. 78 No. 1, pp. 32-36.
- FPT Research (2017), available at: https://static1.vietstock.vn/edocs/5802/Marine_Port_Report_072017_FPTS.pdf
- Gaski, J.F. and Nevin, J.R. (1985), "The differential effects of exercised and unexercised power sources in a marketing channel", *Journal of Marketing Research*, Vol. 22 No. 2, pp. 130-142.
- Gil-Saura, I., Berenguer-Contró, G. and Ruiz-Molina, M.E. (2018), "Satisfaction and loyalty in B2B relationships in the freight forwarding industry: adding perceived value and service quality into equation", *Transport*, Vol. 33 No. 5, pp. 1184-1195.
- Gronroos, C. (1984), "A service quality model and its marketing implications", *European Journal of Marketing*, Vol. 18 No. 4, pp. 36-44.

- Guo, X., Duff, A. and Hair, M. (2008), "Service quality measurement in the Chinese corporate banking market", *International Journal of Bank Marketing*, Vol. 26 No. 5, pp. 305-327.
- Ha, M.-S. (2003), "A comparison of service quality at major container ports: implications for Korean ports", *Journal of Transport Geography*, Vol. 11 No. 2, pp. 131-137.
- Hair, J.H., Anderson, R. and Black, W. (1995), *Multivariate data analysis: with readings* Englewood Cliffs, Prentice-Hall.
- Hair, J.F., Black, W.C., Babin, B.J. and Anderson, R.E. (2010), *Multivariate Data Analysis*, Seventh Edition.
- Hill, N., Brierley, J. and Macdougall, R. (2003), *How to Measure Customer Satisfaction*, Gower, Aldershot.
- Hopkins, S.A., Strasser, S., Hopkins, W.E. and Foster, J.R. (1993), "Service quality gaps in the transportation industry: an empirical investigation", *Journal of Business Logistics*, Vol. 14 No. 1, pp. 145-162.
- Hu, K.C. and Lee, P.T.W. (2017), "Novel 3D model for prioritizing the attributes of port service quality: cases involving major container ports in Asia", *International Journal of Shipping and Transport Logistics*, Vol. 9 No. 6, pp. 673-695.
- Kolanovic, I., Skenderovic, J. and Zenzerovic, Z. (2008), "Defining the port service quality model by using the factor analysis", *Pomorstvo, God*, Vol. 22, pp. 284-285.
- Ladhari, R. (2008), "Alternative measures of service quality: a review", *Managing Service Quality: An International Journal*, Vol. 18 No. 1, pp. 65-86.
- Le, A.-T., Ho, T.-V. and Nguyen, L.-N. (2018), "Study of satisfaction of customers for the quality of sea transport services: case in Tan Cang shipping joint stock Company – Da Nang branch", *International Research Journal of Advanced Engineering and Science*, Vol. 3 No. 4, pp. 220-224.
- Lee, S.-Y., Jose, L.T. and Chang, Y.-T. (2013), "Assessing port service quality by process component: the case of Korean and Chinese ports", *International Journal of Shipping and Transport Logistics*, Vol. 5 No. 2, pp. 137-154.
- Lehtinen, U. and Lehtinen, J.R. (1991), "Two approaches to service quality dimensions", *The Service Industries Journal*, Vol. 11 No. 3, pp. 287-303.
- Litwin (1995), *How to Measure Survey Reliability and Validity*, Thousand Oaks, CA Sage.
- Liao, K.-H. (2012), "Service quality, and customer satisfaction: direct and indirect effects in a B2B customer loyalty framework", *The Journal of Global Business Management*, Vol. 8 No. 1, pp. 86-93.
- Madhani, P.M. (2010), *Resource Based View (RBV) of Competitive Advantage: An Overview*, The Icfai University Press, Hyderabad, pp. 3-22.
- Miremadi, A., Ghalamkari, S. and Sadeh, F. (2011), "Customer satisfaction in port industry – a case study of Iranian shipping", in *2011 International Conference on Sociality and Economics Development*, Vol. 10, pp. 58-62.
- Murphy, P.E. and Ross, S.C. (1987), "Evaluating service firms: approaches with policy recommendations", *Journal of Consumer Policy*, Vol. 10, pp. 363-81.
- Nguyen, C.K.T. and Ngo, Q.T. (2017), *Report of Seaport*, FPT Securities, Hanoi.
- Nguyen, H.V. (2015), "Service quality at the seaport system of Saigon Newport corporation", *International Journal of Marketing Studies*, Vol. 7 No. 6, pp. 145-154.
- Oliver, R. (1997), *Satisfaction: A Behavioral Perspective on the Customer*, McGraw-Hill, Boston, MA.
- Pak, J.Y., Thai, V.V. and Yeo, G.T. (2015), "Fuzzy MCDM approach for evaluating intangible resources affecting port service quality", *The Asian Journal of Shipping and Logistics*, Vol. 31 No. 4, pp. 459-468.
- Pantouvakis, A. (2010), "The relative importance of service features in explaining customer satisfaction", *Managing Service Quality: An International Journal*, Vol. 20 No. 4, pp. 366-387.

- Parasuraman, A., Zeithaml, V.A. and Berry, L.L. (1985), "A conceptual model of service quality and its implications for future research", *Journal of Marketing*, Vol. 49 No. 4, pp. 41-50.
- Parasuraman, A., Zeithaml, V.A. and Berry, L.L. (1994), "Reassessment of expectations as a comparison standard in measuring service quality: implications for further research", *Journal of Marketing*, Vol. 58 No. 1, pp. 111-124.
- Pham, T.-Y. and Yeo, G.-T. (2019), "Evaluation of transshipment container terminals' service quality in Vietnam: from the shipping companies' perspective", *Sustainability*, Vol. 11 No. 5, doi: [10.3390/su11051503](https://doi.org/10.3390/su11051503).
- Rushton, A., Croucher, P. and Baker, P. (2014), *The Handbook of Logistics and Distribution Management*, KoganPage, London.
- Santouridis, I. and Trivellas, P. (2010), "Investigating the impact of service quality and customer satisfaction on customer loyalty in mobile telephony in Greece", *The TQM Journal*, Vol. 22 No. 3, pp. 330-343.
- Seth, N., Deshmukh, S.G. and Vrat, P. (2006), "A framework for measurement of quality of service in supply chains", *Supply Chain Management: An International Journal*, Vol. 11 No. 1, pp. 82-94.
- Slack, B. (1985), "Containerization and Inter C port Competition", *Maritime Policy and Management*, Vol. 12 No. 4, pp. 293-304.
- Ship-Technology (2019), "Lach Huyen international gateway port, Haiphong", available at: www.ship-technology.com/projects/lach-huyen-international-gateway-port-haiphong/
- Tepe, R. (2015), "A study on the service quality components of container shipping", Master's thesis, Dokuz Eylul University, Graduate School of Social Sciences.
- Thai, V.V. (2017), "Assessing the national port system: the case of Vietnam", Pettit, S. and Beresford, A., (eds), (Chapter 15), in *Port Management: Cases in Port Geography, Operations and Policy*, Kogan Page, pp. 407-443.
- Thai, V.V., Tay, W.J., Tan, R. and Lai, A. (2014), "Defining service quality in tramp shipping: conceptual model and empirical evidence", *The Asian Journal of Shipping and Logistics*, Vol. 30 No. 1, pp. 01-29.
- Thai, V.V. (2008), "Service quality in Maritime transport: Conceptual model and empirical evidence", *Asia Pacific Journal of Marketing and Logistics*, Vol. 20 No. 4, pp. 493-518.
- Thai, V.V. (2015), "The impact of port service quality on customer satisfaction: the case of Singapore", *Maritime Economics and Logistics*, Vol. 18 No. 4, pp. 1-18.
- Thamrin, H.M. (2012), "The role of service marketing mix and ship service quality towards perceived value and its impact to ship passenger's satisfaction in Indonesia", *Global Journal of Management and Business Research*, Vol. 12 No. 3, pp. 96-101.
- Ugboma, C., Ibe, C. and Orwude, I.C. (2004), "Service quality measurements in ports of a developing economy: Nigerian ports survey", *Managing Service Quality: An International Journal*, Vol. 14 No. 6, pp. 487-497.
- Van Dyke, T.P., Kappelman, L.A. and Prybutok, V.R. (1997), "Measuring information systems service quality: concerns on the use of the servqual questionnaire", *MIS Quarterly*, pp. 195-207.
- Vietnam Seaports Association (2018), "Statistics 2018", available at: www.vpa.org.vn/statistics-2018/
- Wanke, P.F. and Barros, C.P. (2015), "Public-private partnerships and scale efficiency in Brazilian ports: evidence from two-stage DEA analysis", *Socio-Economic Planning Sciences*, Vol. 51, pp. 13-22.
- World Bank (2007), *World Bank Seaport Toolkit*, 2nd ed., World Bank, Washington, DC.
- Yang, X. and Yip, T.-L. (2019), "Sources of efficiency changes at Asian container ports", *Maritime Business Review*, Vol. 4 No. 1, pp. 71-93.

- Yeo, G.T., Thai, V.V. and Roh, S.Y. (2015), "An analysis of port service quality and customer satisfaction: the case of Korean container ports", *Asian Journal of Shipping and Logistics*, Vol. 31 No. 4, pp. 427-447.
- Yeo, G.T., Thai, V.V. and Roh, S.Y. (2016), "An analysis of port service quality and customer satisfaction: the case of Korean container ports", *The Asian Journal of Shipping and Logistics*, Vol. 31 No. 4, pp. 427-447.
- Yun, G. (2017), "Ghost port: Asia's first fully-automated port begins operations in Qingdao", available at: [CGTN.com,https://news.cgtn.com/news/3d637a4e31677a4d/share_p.html](https://news.cgtn.com/news/3d637a4e31677a4d/share_p.html)

Corresponding author

Vinh V. Thai can be contacted at: vinh.thai@rmit.edu.au